



I'M
AT YOUR
SERVICE

I'M HOTEL

Owned and Operated by Worldhotel Makati, Inc.

reservations@imhotel.com | www.imhotel.com

WHY BOOK DIRECT?



Best Rate Guarantee



Website-only Promotions



More Customized Services



Complimentary Club Lounge Access

Dear Valued Guest,

Mabuhay and welcome to **I'M Hotel**, a place where everything is all about you. I would like to personally welcome you to your address which is the epitome of affordable urban luxury in the heart of Makati. We are very excited that you have chosen to stay with us and will do our best to curate remarkable memories of your stay here.

The next pages will allow you to explore more details of the hotel and its facilities. We also invite you to explore **I'M Onsen Spa** for a serene and calming atmosphere to nourish the mind, body, and spirit. This is the largest urban spa in the country, rated number 1 across Manila and Luzon for the 2nd year running. As an exclusive treat to our in-house guests, you will get to avail a discount on our list prices when you visit our spa, quoting your name and room number.

I'M Hotel also caters to a well-travelled and discerning palate. **The Common Good Food Playground** features nine (9) different concepts under one roof, offering the best of various international cuisines. **Antidote**, located on our roof deck is the very first jellyfish bar in the country with a 360-degree view. Watch the ambient glow of these creatures accentuate the stunning cityscape with a bespoke cocktail in hand. Last but not least, **Mermaid Pool Bar**, located by our iconic acrylic-bottomed pool, dishes up exciting bar nibbles inspired from various corners of the world.

If you've had a long and eventful day, feel free to enjoy the swimming pool, work out at our Fitness Centre or simply lounge at the Club Lounge, a privilege that comes complimentary for suite room guests, and guests who book directly with us.

Here's to wishing you a pleasant stay, we look forward to delighting you with personalized service and providing you with splendid memories!

Heartfelt Regards,

General Manager
I'M Hotel

I'M HOTEL
Owned and Operated by Worldhotel Makati, Inc.
(+632) 7755 7888 | www.imhotel.com



HOTEL FACT SHEET

I'M HOTEL

Owned and Operated by Worldhotel Makati, Inc.

reservations@imhotel.com | www.imhotel.com

WHY BOOK DIRECT?



Best Rate Guarantee



Website-only Promotions



More Customized Services



Complimentary Club Lounge Access



I'M All About You

Modern luxury, personalized service, and the largest spa with the first onsen in the Philippines has landed in the heart of Makati!



I'M HOTEL

(+632) 7755 7888
 info@imhotel.com | reservations@imhotel.com
 www.imhotel.com
 f @ imhotelp



I'M Onsen SPA

(+632) 7755 7877
 spareservations@imhotel.com
 www.imonsenspa.com
 f @ imonsenspa

Book direct with us for the best rates not available anywhere else. Complimentary access to our club lounge also awaits for all direct bookers who reserve via our website, email, or telephone line.

7862 Makati Avenue corner Kalayaan Avenue, Makati City, Philippines 1210

ACCOMMODATION

I'M Hotel is a luxurious 5 star hotel that comprises 434 spacious rooms. Choose from a range of room types that will all give you a great experience.

HOTEL		
Classic Studio	King	30 sqm
Indulgence	King	34 sqm
Prestige	Twin	37 sqm
Executive Prestige King	King	40 sqm
Executive Prestige Twin	2 Double	40 sqm
Premier Suite	1 King	44 sqm
1 BR Executive Suite	1 King	57 sqm
2 BR Junior Suite	1 King per Room	76 sqm
2 BR Executive Suite	2 Single / 1 King	100 sqm

AMENITIES

(Classic, Indulgence, Prestige and Executive Prestige)

Complimentary WiFi • Complimentary minibar • 49-inch LED television • Executive writing desk • Local and IDD telephone • Coffee / Tea • In-room safe • Ironing facilities • Hair dryer • Toiletries • Rain showerhead • Separate shower and bathtub in selected rooms • Designer Bath Amenities

AMENITIES

(Premier Suite, Junior Suite, and Executive Suite)

Complimentary WiFi • Complimentary minibar • 49-inch LED television • Pillow Menu • Executive writing desk • Local and IDD telephone • Coffee / Tea • In-room safe • Ironing facilities • Hair dryer • Toiletries • Rain showerhead • Separate shower and bathtub in selected rooms • Separate living room • Kitchenette with cooking facilities • Dining area • Refrigerator • Private laundry facility • Microwave oven • Designer Bath Amenities • Balcony in selected suites

HOTEL FACILITIES

Complimentary WiFi • Acrylic-Bottomed Swimming Pool • Fitness Center • Business Center • Ballroom • Restaurants • Club Lounge • I'M Onsen Spa • Flower Shop

NEIGHBORHOOD

I'M Hotel is located along the bustling Makati Avenue, just a stone's throw away from the city's Central Business District. The hotel offers easy access to key locations and sites, including Greenbelt, Ayala Triangle, BGC, Century City and Rockwell. It is a mere 7.5km from Ninoy Aquino International Airport.

AT YOUR SERVICE

In-room dining • Dry cleaning and laundry • Shoe shine • Private Airport Transfers • Valet Service

DINING & ENTERTAINMENT

The Common Good Food Playground (All-Day Dining)

Operating Hours: Daily
 Breakfast (Buffet): 6:00 AM to 10:00 AM
 Lunch (A la Carte): AVAILABLE VIA IN-ROOM DINING SERVICE
 Dinner (Buffet): 5:00 PM to 10:00 PM

The Common Good unites everyone with a shared love of food. It features 9 different concepts under one roof, offering the best of various international cuisines:

- Parilla (Barbeque & Grill section) • Al Dente (Italian)
- Paul and Ranuka (Healthy Instagramable Eats) • Empress Jade (Modern Chinese) • Perfect Four • One Bowl Wonder (Japanese Donburi and Hong Kong Roast Meats) • Tiffin (Indian) • Fountain (Seasonal Healthy Drinks) • Sucré (Dessert Station)

Mermaid (Globally Inspired Nibbles and Tipples)

Operating Hours: Daily, 3:00 PM - 11:00 PM
 Mermaid is a celebration of good food and music. Located by our iconic acrylic-bottomed pool, the bar attracts a hip and modern crowd by dishing up exciting bar nibbles inspired from various corners of the world. These delectable morsels are best paired with our cocktails and spirits.

Antidote Rooftop Bar (Tapas & Bespoke Cocktails)

Operating Hours: Sunday - Thursday, 5:00 PM to 2:00 AM
 Friday - Saturday, 6:00 PM to 3:00 AM
 The bar features bespoke cocktails and tapas. The highlight of the bar is a luminescent jellyfish tank, where the ambient glow of these creatures accentuates with the backdrop of the stunning cityscape.

Venue	Area	CAPACITY			
		U-Shape	Cocktail	Round Table	Fashion Show
Lower Deck	565 sqm	Upon Request	120	92	Upon Request
Upper Deck	477 sqm	-	110	220	Upon Request

For group/table reservations and other enquiries:
 (+63 2) 7755 7899 (during Operating Hours)
 sales@imhotel.com • www.imhotel.com

MEETINGS & SOCIAL EVENTS

Our unique and modern meeting rooms can cater to your every event need. Our ballroom can accommodate large-scale meetings that require different kinds of set-ups including theater, classroom, boardroom, u-shape, cabaret and hollow square. I'M Onsen Spa also has a variety of modern and well-appointed venues suitable for smaller groups.

Venue	Capacity	Location	Area
Narra Ballroom	335	5th Floor	504 sqm
Acacia Room	95	6th Floor	169 sqm
Mahogany Room	70	6th Floor	123 sqm
Banyan Room	50	6th Floor	80 sqm
Palmera Room	50	6th Floor	80 sqm
VIP Spa Suites*	25	Mezzanine 1	39-52 sqm
Meeting Rooms*	25	Basement 1	39-52 sqm

VIP Spa Suites ranging from 39-52 sqm.
 Meeting Rooms ranging from 39-52 sqm.

I'M ONSEN SPA

Operating Hours: Monday - Thursday, 12:00 NN to 2:00 AM
 Friday - Sunday, 10:00 AM to 3:00 AM

An expansive and lush urban oasis that is the largest in Manila, spanning 3800 sqm across 6 storeys. Guests can choose to have their treatments in a wide variety of rooms, from spa pods to couple suites with ensuite jacuzzis or steam rooms, and VIP spa suites fit for small exclusive gatherings. "Onsen" is Japanese for hot spring, and I'M Onsen Spa houses the first authentic Japanese thermal bath in the country, using proprietary technology that mimics the mineral composition of hot springs in Japan. The experience comes with complimentary herbal teas, and includes a wholesome buffet meal at The Common Good Food Playground. Access to the relaxation lounge and facilities are also included.

For reservations and other enquiries:
 (+632) 7755 7877 • spareservations@imhotel.com
 • www.imonsenspa.com

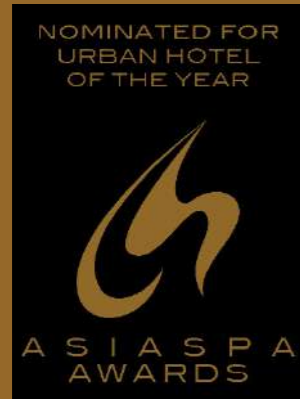

I'M SERVICES DIRECTORY

I'M HOTEL

Owned and Operated by Worldhotel Makati, Inc.

reservations@imhotel.com | www.imhotel.com

WHY BOOK DIRECT?



Best Rate Guarantee



Website-only Promotions



More Customized Services



Complimentary Club Lounge Access

I'M SERVICES DIRECTORY

Please contact our friendly service desk by dialling "1" on your telephone should you need any of the following services. For your convenience, the relevant information is already provided under each headline.

AIR CONDITIONING

A wall-mounted cooling control in your room is provided to set your desired temperature. Please refer to our "How-To's" section for more information.

AIRLINE INFORMATION

Our concierge will be glad to assist you with your flight information, reconfirmation, and airline schedules. Please press the service key "1" for assistance. Should you wish to contact the concierge directly, please dial loc. 622.

AIRPORT CONNECTIONS

I'M Hotel is approximately 7.5 kilometers away from the Ninoy Aquino International Airport. To book your car transfer, simply provide your flight carrier, flight number, and estimated time of arrival.

Other International Airports near Manila:

Clark International Airport – 108 kilometers away

Subic Bay International Airport - 170 kilometers away

BABYSITTING

Please press the service key "1" for more information or assistance. Baby cots are complimentary and provided upon request, subject to availability. A 3-hour babysitting fee of Php 900 will apply.

BANKING

Please approach the concierge desk for assistance or guidance to nearby banks.

BDO

Gramercy Residences, Salamanca Street

(+632) 556 9329, 8:30 AM to 5:30 PM

Turn right to Makati Avenue, turn left to Eduque Street.

MAYBANK

St. Giles Hotel Corner Makati Avenue

(+632) 553 8115, 9:00 AM to 4:00 PM

Turn left to Makati Avenue, turn left to Kalayan Avenue beside of the hotel.

UNION BANK

7842 Makati Avenue

(+632) 895 1774, 9:00 AM to 4:00 PM

Turn left to Makati Avenue, two (2) blocks away from the hotel just across 7-Eleven convenience store.

BPI FAMILY SAVINGS BANK

7838 Makati Avenue

(+632) 577 5400, 9:00 AM to 4:30 PM

Turn right to Makati Avenue, four (4) blocks away from the hotel.

I'M HOTEL

Owned and Operated by Worldhotel Makati, Inc.

(+632) 7755 7888 | www.imhotel.com

- EASTWEST BANK** Unit 2 A and W Building, Makati City
(+632) 880 0526, 9:00 AM to 5:00 PM
Turn left to Makati Avenue, four (4) blocks away from the hotel, located just across Kenny Rogers.
- SECURITY BANK** G/F Gramercy Residences, Kalayaan Avenue
(+632) 403 7505, 9:00 AM to 5:00 PM
Turn right to Makati Avenue, turn left onto Eduque Street, beside BDO.
- CHINA BANK** G/F CBC Building, Makati Avenue corner Hercules Street
(+632) 890 6971, 9:00 AM to 4:00 PM
Turn left to Makati Avenue, three (3) blocks away from the hotel.
- AUB BANK** G/F Traveller's Inn Condominium, 7880 Makati Avenue
(+632) 890 0694, 9:00 AM to 5:00 PM
Turn left to Makati Avenue, three (3) blocks away from the hotel.
- PS BANK** 690 Makati Avenue
(+632) 896 0014, 9:00 AM to 5:00 PM
Turn left to Makati Avenue, five (5) blocks away from the hotel.

BUSINESS SERVICES Please dial loc. 120 for more information or assistance. Our friendly club lounge agent will be there to assist you.

BATH AMENITIES Explore our signature bath and body collections designed to rejuvenate your body and mind. Your rooms are provided with towels and toiletries based on the number of registered occupants.

CAR SERVICE AND AIRPORT TRANSPORTATION Airport transportation is only from Php 2,000 per way. Please dial 1 for more information or assistance. Alternatively, please dial 622 to reach the concierge directly.

CATERING (MEETINGS AND SOCIAL EVENTS) Should you be interested in viewing or booking our banquet spaces for your corporate or social events, please email events@imhotel.com and a dedicated sales manager will get back to you regarding your request.

CHECK-IN/ CHECK-OUT TIME Check In: 2:00 PM
Check Out: 12:00 NN

Kindly note that check-in time may be shifted to 3:00 PM during high occupancy periods.

CONCIERGE Our concierge desk is located at the lobby of the hotel.

CLUB LOUNGE Our club lounge is located at the Upper Ground floor. Club lounge access is a privilege granted to suite room guests and guests who book direct. Full day refreshments are available from 7:00 AM to 11:00 PM.

CONFERENCE FACILITIES AND SOCIAL EVENTS VENUE While with us, please do not hesitate to ask for an ocular visit to our Grand Ballroom and meeting rooms. Please dial "1" for assistance. Arrangements for the following event venues can be made in advance through our Sales Team. Please email sales@imhotel.com.

FUNCTION ROOM	LOCATION	CAPACITY	AREA
Narra Ballroom	5Th Floor	400	504 Sqm
Acacia Room	6Th Floor	100	169 Sqm
Mahogany Room	6Th Floor	60	123 Sqm
Banyan Room	6Th Floor	50	80 Sqm
Palmera Room	6Th Floor	50	80 Sqm
Vip Spa Suites	Mezzanine 1	12	39-52 Sqm
Meeting Rooms	Basement 1	12	39-52 Sqm

COURIER SERVICE Your Concierge will be glad to assist you with your mails, packages, and messages. Please dial the service key "1" for assistance. Alternatively, you may reach the concierge directly by dialing 622.

CREDIT CARDS We honor all major credit cards (Visa, MasterCard, Amex, JCB, Diners, China, UnionPay). Please present your credit card upon check-in.

DINING OUTLETS **ANTIDOTE**, Tapas & Bespoke Cocktails
Located on the Roof deck (RD), Antidote bar features bespoke cocktails and tapas accompanied with a breathtaking view of the city skyline. The highlight of the bar is a luminescent jellyfish tank, where diners can enjoy the ambient glow of these elegant creatures in the backdrop of the stunning cityscape.
Operating Schedule: Sunday to Thursday, 5:00 PM to 2:00 AM
Friday and Saturday, 6:00 PM to 3:00 AM



Please email antidotebarph@imhotel.com for table reservations and sales@imhotel.com for larger group or event bookings.



THE COMMON GOOD FOOD PLAYGROUND, All-day Dining

The Common Good unites everyone with a shared love of food. It features nine (9) different concepts under one roof, offering the best of various international cuisines.

Dining Concepts:

• Parilla (Barbeque & Grill section) • Al Dente (Italian) • Paul and Ranuka (Healthy Instagramable Eats) • Empress Jade (Modern Chinese) • Perfect Four (or in Chinese 完美 便当) – Economical Rice • One Bowl Wonder (Japanese Donburi and Hong Kong Roast Meats) • Tiffin (Indian delights from breakfast to dinner and anything in between) • Fountain (Modern Healthy Beverages) • Sucre (Dessert Station)

Operating Schedule: Daily, 6:00 AM to 10:00 PM

Breakfast Buffet: 6:00 AM to 10:00 AM

Lunch A la Carte: (ALA CARTE) AVAILABLE VIA IN-ROOM DINING SERVICE

Dinner Buffet: 5:00 PM to 10:00 PM



MERMAID, Globally Inspired Nibbles and Tipples

Mermaid is a celebration of good food and good music. Located by our iconic acrylic bottomed pool at the 2nd level, the bar attracts a hip and modern crowd by dishing up exciting bar nibbles inspired from various corners of the world. Guests can also pair these delectable morsels with some of the city's best cocktails and spirits. The bar opens in the evening onwards.

Operating Schedule: Daily, 11:00 AM to 11:00 PM



HOPS AND BREWS, Cafe by Day, Bar by Night (Tenant)

Hops & Brews offer great drinks from morning 'til late at night: from our specialty coffees based on single origin beans to power up your day to our classic cocktails to satisfy your thirst at the end of the day.

Operating Schedule: Daily, 10:00 AM to 2:00 AM

DUTY MANAGER

Please dial service key "1" for assistance.

ELECTRICITY / VOLTAGE

The electricity is at 220 volts /60 hertz.

ELEVATOR

We are equipped with six (6) guest elevators (3 high rise, 3 low rise elevators) and two (2) separate elevators serving the spa floors. Guest elevators are equipped with a high-level security feature that enables guests to access each designated floor using a keycard.

EXTRA BEDS

Extra bed set up can be arranged for additional guests upon request. This is applicable for the Indulgence room category and beyond for only Php 1,800 nett per person with breakfast. Please dial "1" for more assistance.

I'M HOTEL

Owned and Operated by Worldhotel Makati, Inc.
(+632) 7755 7888 | www.imhotel.com

FITNESS CENTER

Situated on the Mezzanine (M1) floor, our state-of-the-art gym facilities powered by Life Fitness.

Operating Schedule: Daily, 6:00 AM to 12:00 AM

GIFT CARDS/GIFT CERTIFICATES

Give the gift of an I'M experience to your friends, colleagues, or business associates! Gift certificates are available for purchase for the hotel, spa, and food and beverage outlets. Kindly approach our friendly front desk for assistance.

HOUSEKEEPING

24-hour housekeeping services are available. Shoe shine service is offered to guests upon request. Please press service key "1" for assistance.

ICE

This is available upon request. Please press service key "1" for assistance.

INDUCTION COOKER

Induction cookers are available for your convenience within all suite rooms. Please refer to our "How-To's" section for more information.

INTERNET

Stay connected during your stay with 40MB bandwidth internet service provided throughout our guestrooms and public areas. Please log-in with your username and password provided at check-in. User name is your room no. Password is *followed by room no. eg: USER NAME: 2803 PASSWORD: *2803

IN ROOM DINING/ PRIVATE DINING

Delectable cuisine is available at your fingertips. In-room dining is available 24 hours. Kindly refer to the Private Dining Menu provided in this compendium. Please dial "230" for assistance. You may also directly order by selecting the relevant menu section on our smart television system.

I'M ONSEN SPA

From the Upper Ground (UG) lobby, start your journey to the 6-level Onsen Spa, the expansive sanctuary that houses the first authentic Japanese thermal bath in Manila, relaxation lounges, and a buffet restaurant. I'M Onsen Spa is proudly ranked the top spa on Tripadvisor for Metro Manila and Luzon.

IRONING FACILITIES

Iron and Ironing board are available in all rooms. These are located within the cupboards.

LAUNDRY AND DRY CLEANING SERVICE

You may now travel light! Our professional laundry and dry cleaning services will handle your belongings with utmost care at a reasonable rate. Please press service key "1" for assistance.

We request that laundries or clotheslines should not be exposed to public view.

I'M HOTEL

Owned and Operated by Worldhotel Makati, Inc.
(+632) 7755 7888 | www.imhotel.com

LOST AND FOUND To report missing items, please dial service key "1" for assistance.

LUGGAGE STORAGE Please press the concierge service key "622" for assistance.

MEDICAL SERVICES For medical requirements, our Front Office will be glad to arrange an appointment for you with an accredited physician. Please dial service key "1" for assistance.

NEWSPAPERS Local newspapers are available upon request.

PARKING To preserve the clean air within the hotel, please turn off car engines while parked. In-house guests are entitled to one (1) complimentary parking slot per room during their stay. Because parking slots are limited, slots will be on a first come, first served basis. Kindly present your car park ticket to our concierge or front desk for validation

PETS As much as we love pets, unfortunately, we are unable to accommodate them in our rooms or any of our common areas. We can refer you to the local pet house, while you choose to stay with us.

PET EXPRESS
Osmeña Highway, corner Finlandia St., Makati
(+632) 8836 8955

PRIVACY For rooms, we have an electronic "Do Not Disturb" button located by the door next to "Make up Room" button. For suites, a physical door tag is provided to hang outside your door to serve the same purpose. You may also request the front desk to take messages for you during this time.

RESERVATIONS For room reservations at I'M Hotel, please email reservations@imhotel.com or visit www.imhotel.com. Direct bookers enjoy a best rate guarantee and other exclusive perks such as complimentary club lounge access, and more.

SAFE DEPOSIT BOX Your safety is our business. For your security and convenience, we strongly recommend that all valuables be kept in your safe for the duration of your stay. The management shall not be held liable for any loss within the hotel premises.

SALES DEPARTMENT For corporate, group, and event enquiries, please email events@imhotel.com.

SECURITY We would like to reassure you that we maintain strict security at the hotel on a 24-hour basis. For immediate assistance, please dial service key "1".

SIGHTSEEING AND TOURS Local information, car rentals, directions, and reservations for sightseeing in Manila can be found at the concierge desk located at Lower Ground (LG) floor.

SMOKING Healthier. Happier. Fresher. I'M Hotel is committed to catering to the needs of all guests. A designated smoking area is located on the 4th floor for your convenience. However, usage of shisha, cigarettes, and electronic cigarettes is prohibited in all guest rooms. A fee equivalent to Php 10,000.00 per incident will be charged to your account if a smoking incident occurs in your room during your stay.

- ددحو اولو هلدلل / وسىب 10,000 : نىخدتل لةم ارغنى خدتل لمدعل اركش
- 禁止吸烟 罚款 PHP 10,000
- 禁煙にご協力下さい。 ※違反した場合は、罰金10,000ペソの支払いが課せられます。

SWIMMING POOL Get ready to make your swimming an elevated and sensorial experience! Our acrylic-bottom swimming pool is located on the 2nd floor. Guests entering the hotel will be treated with the glistening water of the pool when they look up. Maximum depth of the pool is 4 feet. Operating Schedule: Daily, 7:00 AM to 9:00 PM

TELEPHONE Stay connected to your friends and family by dialing "9" for outside calls. Local outside calls made from within your room are free of charge. Charges may apply for overseas calls.

TRANSFERS A great way to enjoy your trip while on vacation is to drive around the metro in style. For transfer requirements, please press service key "1" for assistance.

VEHICLE	RATE PER WAY
Sedan	Php 2,000
Multi-purpose Vehicle	Php 2,400
Van	Php 2,900

WAKE-UP CALLS Make your way out of bed with our timely wake-up call. Please press service key "1" for assistance.

WASHING MACHINE Washing machines are available for your convenient use in all suite rooms. Please refer to our "How-To's" section for more information.



HOW TO'S

I'M HOTEL

Owned and Operated by Worldhotel Makati, Inc.

reservations@imhotel.com | www.imhotel.com

WHY BOOK DIRECT?



INDUCTION COOKER OPERATING INSTRUCTIONS

Induction cookers are available for your convenience in all suite rooms

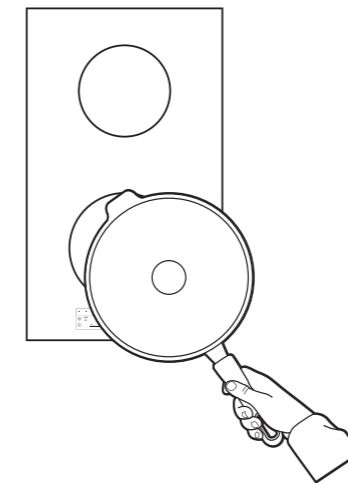

1 Carefully place a suitable cooking pot on top of the circular cooking zone of the induction cooker to activate control panel. Choose the diameter that fits the cooking pot. Please note that all cooking pots must be magnetic.

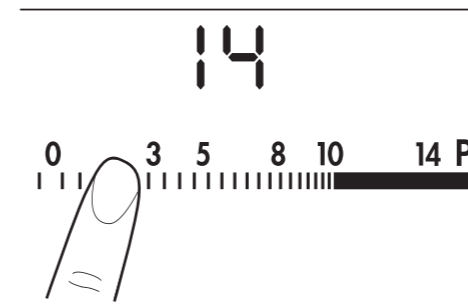

3 Touch and slide the control bar to adjust to your desired heat strength then release. The display will show the current heat setting.

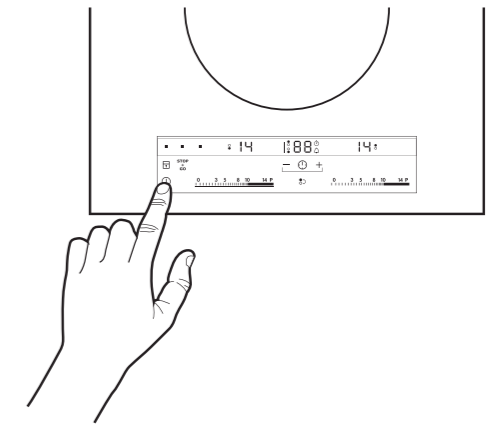

2 To turn **ON**, touch and hold the on/off button for two seconds.

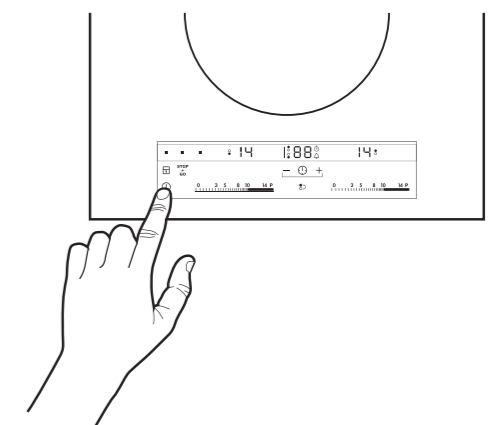

4 To turn **"OFF"**, touch and hold the on/off button for one (1) second.

5 To use the timer, select cooking zone then touch the clock. Touch the plus/minus sign to your desired time.

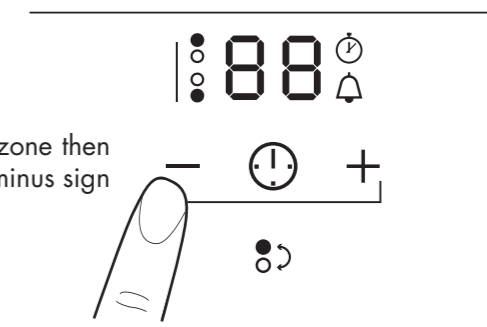

I'M HOTEL

Owned and Operated by Worldhotel Makati, Inc.
 (+632) 7755 7888 | www.imhotel.com

AIRCONDITIONER OPERATING INSTRUCTIONS

A wall-mounted cooling control in your room is provided to set your desired temperature

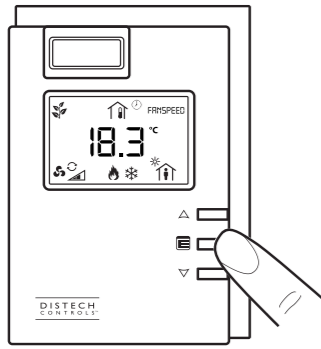

1 To turn **ON** the air conditioner, press the function button once, to set the air conditioner into **"FAN SPEED"** function. It will be shown in the upper right corner of the display panel.

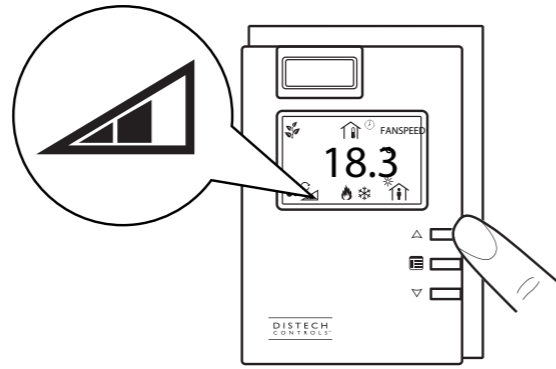

2 Press the **"UP"** or **"DOWN"** button to turn **ON** the air conditioner and adjust to the desired speed of low, medium, or high. You may view the current speed at the display panel located lower left corner of the cooling control.

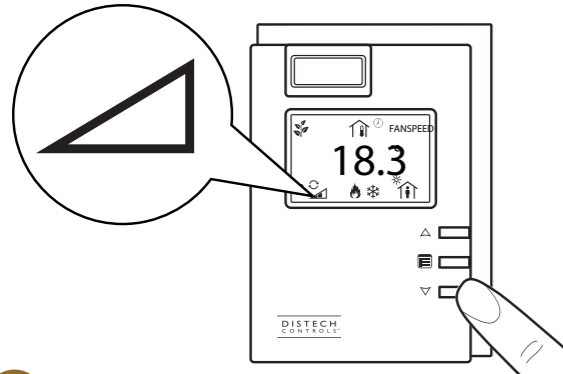

3 To turn the unit **"OFF"**, press the **"UP"** or **"DOWN"** button again, until the speed is off at the display panel of the cooling control.

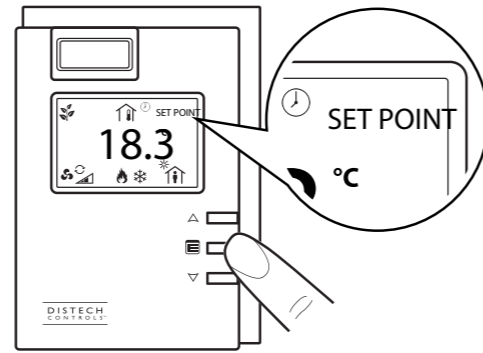

4 To adjust the temperature, press the function button to set into **"SET POINT"** function. It will be shown in the upper right corner of the display panel.

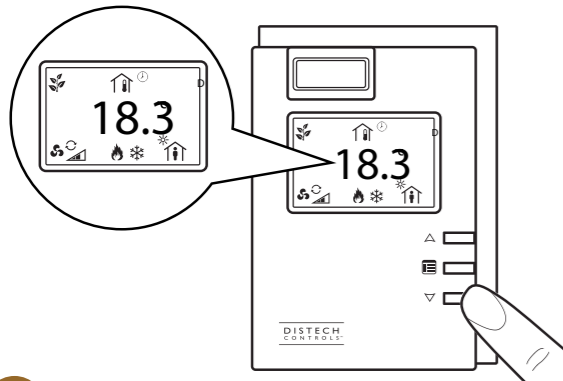

5 Press the **"UP"** or **"DOWN"** button to adjust to your desired temperature. Set point will be shown in the middle of the display panel.

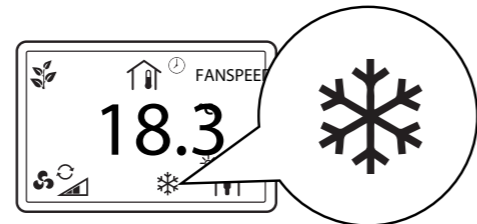

6 A snow flake icon will be displayed in the lower mid-portion of the panel if the current temperature set point you set is lower than the temperature of your room. This means your air conditioner will cool down your room

7 A fire icon will be displayed in the panel if the current temperature set point is higher than the room temperature. The air conditioner will **NOT** cool down your room.

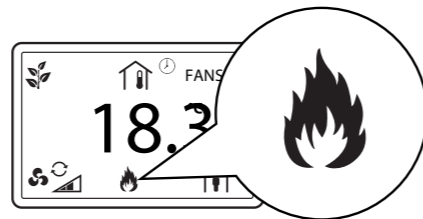

I'M HOTEL

Owned and Operated by Worldhotel Makati, Inc.
(+632) 7755 7888 | www.imhotel.com

WASHING MACHINE OPERATING INSTRUCTIONS

Washing machines are available for your convenient use in all suite rooms

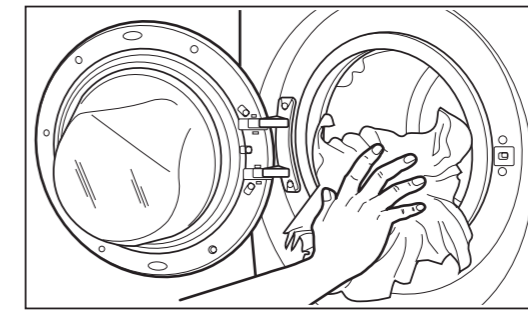

1 Place clothes inside the washing machine tub, then close the machine door.

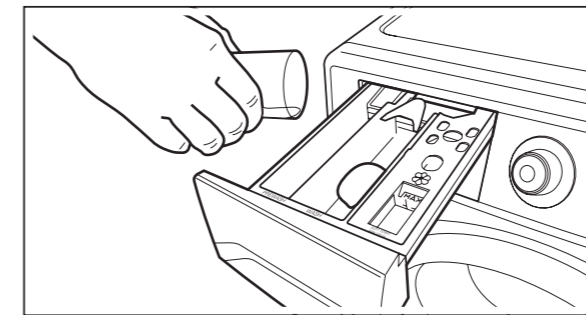

2 Pour in the detergent inside the detergent dispenser drawer located on the upper left side of the equipment. Three (3) compartments are inside the dispenser drawer:

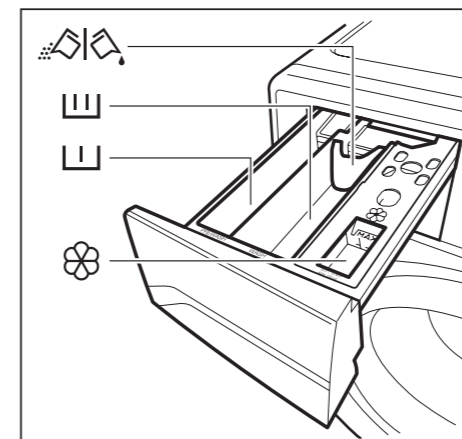

The detergent dispenser is divided into three compartments.

- Detergent flap
Flap for powder or liquid detergent.
- Compartment **'PREWASH'**
This compartment is only used for detergent when a Prewash is selected.
- Compartment **'MAIN WASH'**
This compartment is used for detergent on all programs.
- Compartment **'SOFTENER'**
This compartment is used for fabric conditioner and starching agent.

Powder or liquid detergent.

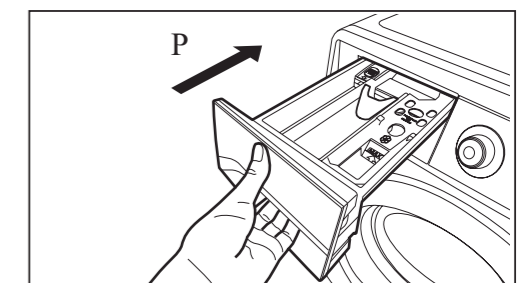
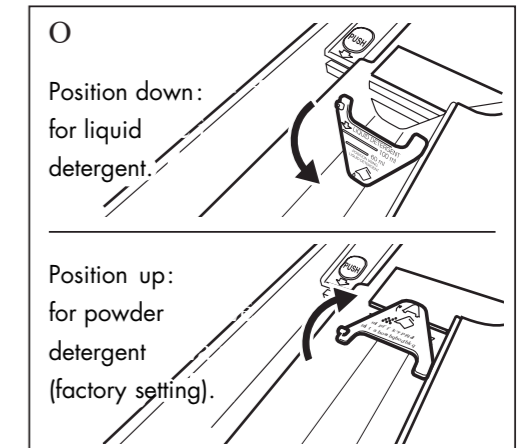
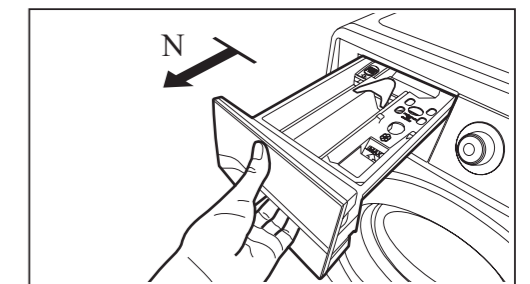

I'M HOTEL

Owned and Operated by Worldhotel Makati, Inc.
(+632) 7755 7888 | www.imhotel.com

COOKER HOOD OPERATING INSTRUCTIONS

Cooker hoods are available for your use in all suite rooms

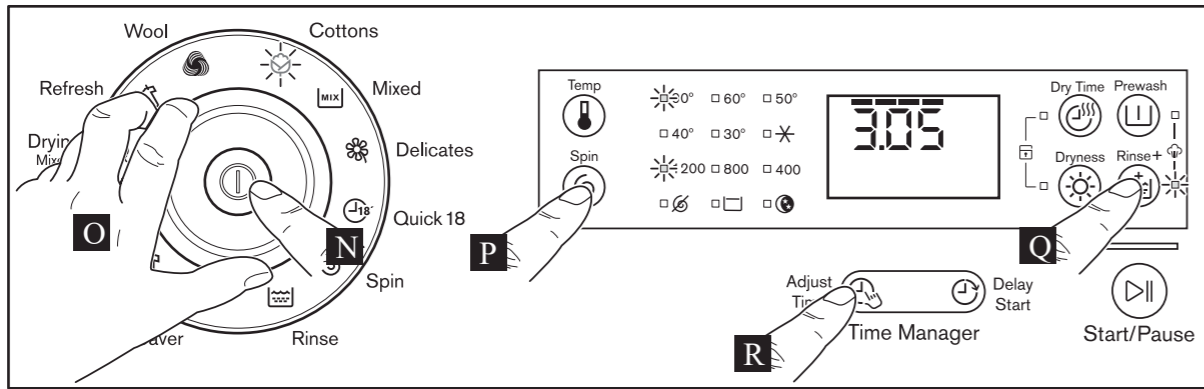

- 3 Select the desired program to wash your clothes. Kindly note that each program has a recommended setting and time

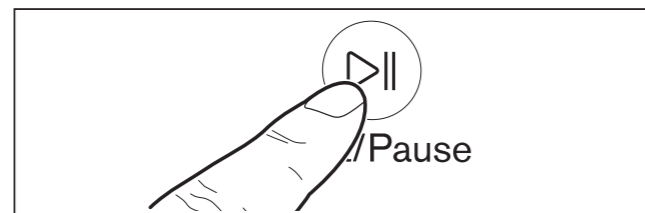

- 4 Press the play button to start the washing machine.

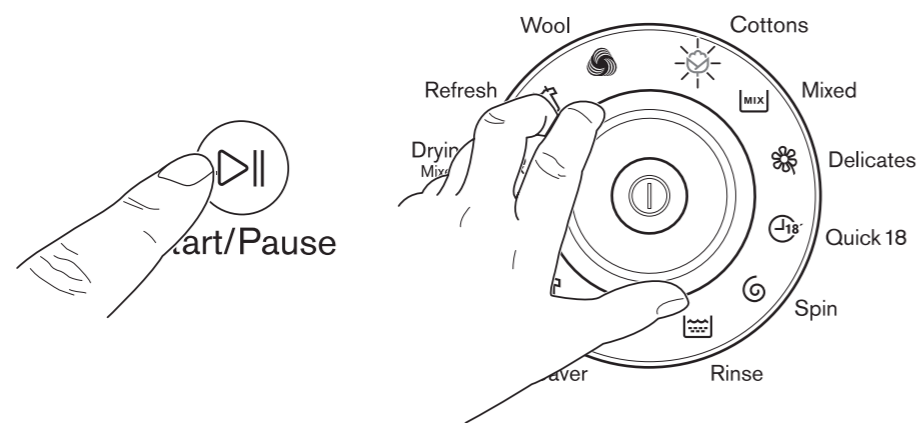

- 5 If you want to change the program, simply press the pause button then turn the selector knob to OFF position. Select the desired program again, then press play.

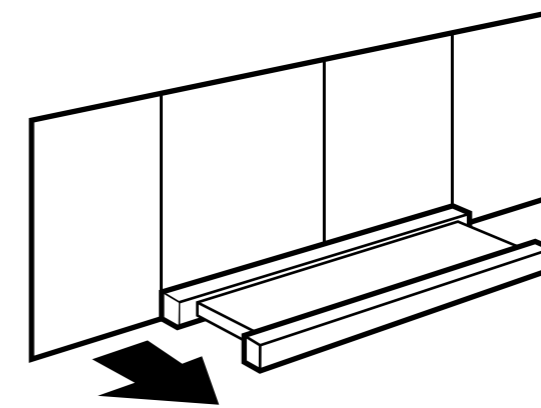

- 1 To turn **ON** the range hood exhaust fan and lights, pull the hood drawer slowly until fully open.

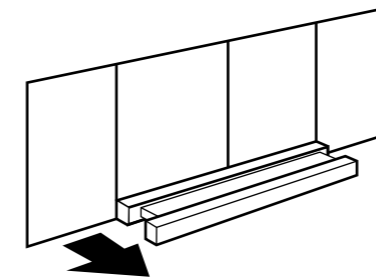

LOW SPEED

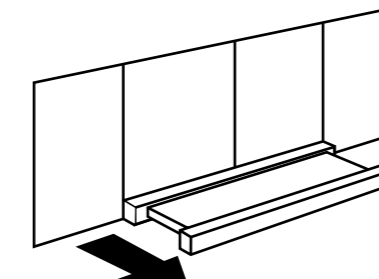

MEDIUM SPEED

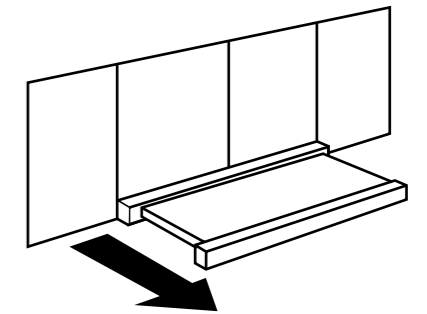

HIGH SPEED

- 2 To adjust the exhaust fan speed, gradually pull or retract the hood until desired speed.

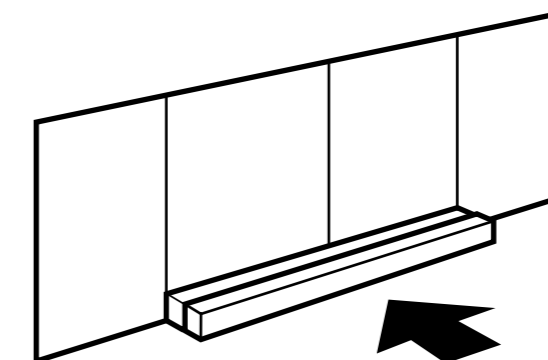

- 3 To turn **OFF**, fully retract the hood to its original position.

I'M HOTEL

Owned and Operated by Worldhotel Makati, Inc.
(+632) 7755 7888 | www.imhotel.com

I'M HOTEL

Owned and Operated by Worldhotel Makati, Inc.
(+632) 7755 7888 | www.imhotel.com

GENERAL EVACUATION PROCEDURES

All Guests and visitors are expected to observe the Hotel's guidelines and procedures in case of an emergency.

When an alarm or siren is heard within the building, kindly adhere to the following procedures:

1. Please do not panic. Remain calm at all times.
2. If you are not sure what to do, call our service center or dial "1" to verify the alarm.
3. When the operator confirmed the evacuation, please follow the next procedures:
4. Disconnect all appliances that you have plugged into the outlets such as hair dryers, razors, and flat iron.
5. Pull out your key card to switch off the power of your assigned hotel room.
6. Bring only valuables that are essential including your mobile phones and wallet.
7. If you need assistance or do NOT know where to go, wait for the room attendant to go to you. They will be with you shortly.
8. If you leave your room alone, always put yourself first before offering help to others.
9. Listen to the building announcement carefully for your safety and guidance.
10. DO NOT USE ELEVATORS. Walk fast but DO NOT RUN. Follow the exit signage leading to the stairwell then to the ground floor.
11. After getting out of the building, be attentive from possible falling objects, cars or trucks crossing, and to the surroundings and people around you.
12. Proceed to the safe refuge or assembly area and speak to the command post or emergency brigade team for further announcement, updates, and help.

I'M HOTEL

Owned and Operated by Worldhotel Makati, Inc.
(+632) 7755 7888 | www.imhotel.com

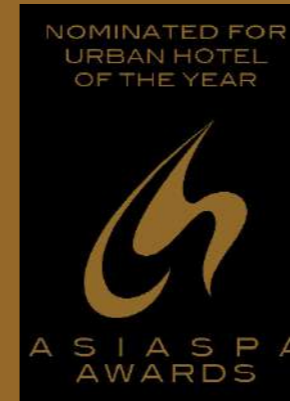

CITY GUIDE

I'M HOTEL

Owned and Operated by Worldhotel Makati, Inc.

reservations@imhotel.com | www.imhotel.com

WHY BOOK DIRECT?



Best Rate Guarantee



Room Service Promotions



More Customized Services



Complimentary Club Lounge Access

BUSINESS & COMMUNITY SERVICES

EMBASSIES

AUSTRALIA

Australian Embassy

Address: 23rd Floor, Tower 2, RCBC Plaza 6819 Ayala Ave., Makati City
Postal Address: P.O. Box 1071 MCPO Makati City
Telephone: (+632) 7757 8100 (Trunk Line)
Fax: (+632) 7757 8268 (Admin)
Email: info@austrade.com.ph (Australia Trade Commission)
manila.consular@dfat.gov.au (Consular Section)
Website: <http://www.philippines.embassy.gov.au>
Working Hours: Monday-Friday (8:00 AM – 4:30 PM)

CANADA

Embassy of Canada

Address: Levels 6 - 8, Tower 2 RCBC Plaza 6819 Ayala Avenue, Makati City 1200
Postal Address: P. O. Box 2168 Makati Central Post Office 1261 Makati City
Telephone: (+632) 8857 9000
Fax: (+632) 8843 1075 (Assistant to the Ambassador)
Email: manilaimmigration@international.gc.ca
Website:
Working Hours: Monday-Friday (8:00 AM – 4:30 PM)

CHINA

Embassy of the People's Republic of China

Address: 4896 Pasay Road, Dasmariñas Village, Makati City
Postal Address: P. O. Box 2168 Makati Central Post Office 1261 Makati City
Telephone: (+632) 8848 2395
Fax: (+632) 8845 2465 (Administrative Section)
Email: Chinaemb_ph@mfa.gov.cn
Website: http://ph.china_embassy.org/eng
Working Hours: Monday-Friday (8:00 AM – 5:00 PM)

EMBASSIES

JAPAN

Embassy of Japan

Address: 2627 Roxas Boulevard, Pasay City 1300
Postal Address: P.O. Box 414, Pasay Central Post Office
Telephone: (+632) 8551 5710
Fax: (+632) 8551 7590 Administration
Email:
Website:
Working Hours: Monday-Friday (8:00 AM – 4:30 PM)

KOREA

Embassy of the Republic of Korea

Address: 122 Upper McKinley Road, McKinley Town Center, Fort Bonifacio, Taguig City 1634
Postal Address: P. O. Box 2168 Makati Central Post Office 1261 Makati City
Telephone: (+632) 8856 9210
Fax: (+632) 8856 9008 Ambassador's Office
Email: koreanembassy.ph@gmail.com
Website: http://embassy_Philippines.mofa.go.kr
Working Hours: Monday-Friday (8:00 AM – 5:00 PM)

MALAYSIA

Embassy of Malaysia

Address: 107 Tordesillas St., Salcedo Village Makati City
Postal Address:
Telephone: (+632) 8662 8200
Fax: (+632) 8662 8201 to 02 (Administrative Section)
Email: mwmanila@kln.gov.my
Website:
Working Hours: Monday-Friday (8:00 AM – 4:00 PM)

I'M HOTEL

Owned and Operated by Worldhotel Makati, Inc.
(+632) 7755 7888 | www.imhotel.com

I'M HOTEL

Owned and Operated by Worldhotel Makati, Inc.
(+632) 7755 7888 | www.imhotel.com

EMBASSIES

TAIWAN

Taiwan Embassy

Address: 41F Tower 1 RCBC Plaza, Ayala Ave, Makati City
Postal Address: P.O. Box 414, Pasay Central Post Office
Telephone: (+632) 8887 6688 (Trunk Line)
Fax: (+632) 8887 7679 (Admin)
Email: phl@mofa.gov.tw
Website: <http://www.taiwanembassy.org/ph>
Working Hours: Monday-Friday (8:45 AM – 4:45 PM)

UNITED KINGDOM OF GREAT BRITAIN AND NORTHERN IRELAND

Embassy of the United Kingdom of Great Britain and Northern Ireland

Address: 120 Upper McKinley Road, McKinley Hill, Taguig City 1634
Postal Address: P.O. Box 2927 Makati City
Telephone: (+632) 8858 2200 (Trunkline)
Fax: (+632) 8858 2305 (Visa)
Email: ukinthephilippines@fco.gov.uk
Website: <http://ukinthephilippines.fco.gov.uk/en>
Working Hours: Monday-Friday (8:00 AM – 5:00 PM)

UNITED STATES OF AMERICA

Embassy of the United States of America

Address: 1201 Roxas Boulevard Manila 1000
Postal Address: P.O. Box 151 Manila
Telephone: (+632) 5301 2000
Fax: (+632) 5301 2017
Email: manilavisitorshelpdesk@state.gov
Website: <http://philippines.usembassy.gov>
Working Hours: Monday-Friday (8:00 AM – 4:30 PM)

HOSPITALS / CLINICS

MAKATI MEDICAL CENTER

Address: No. 2, Amorsolo St., Legaspi Village, Makati City 1229
Telephone: (+632) 8888 8999
Email: mmc@makatimed.net.ph
Website: www.makatimed.net.ph

OSPITAL NG MAKATI

Address: Sampaguita Street, Pembo, Makati City 1218
Telephone: (+632) 8882 6316-18

CLINICA CARITAS - MAKATI

Address: 10/F, Units 1003, 1014-1015 Medical Plaza Makati Bldg., Amorsolo corner Dela Rosa Street, Legaspi Village, Makati City
Telephone: (+632) 8843 8673 / 8843 8681
Email: marketing_services@caritashealthshield.com.ph
Website: www.caritashealthshield.com.ph
Working Hours: Monday-Friday (8:00 AM – 5:00 PM)

HEALTHWAY GREENBELT 5 AYALA CENTER

Address: 4th Floor Greenbelt 5, Ayala Center, Makati City
Telephone: (+632) 7720 6109 / (+63) 917 874 6084
Email: customer_service@healthway.com.ph
Website: <https://healthway.com.ph>
Working Hours: Everyday 7:00 AM - 8:00 PM

I'M HOTEL

Owned and Operated by Worldhotel Makati, Inc.
(+632) 7755 7888 | www.imhotel.com

I'M HOTEL

Owned and Operated by Worldhotel Makati, Inc.
(+632) 7755 7888 | www.imhotel.com

RELIGIOUS SERVICES

SANTUARIO DE SAN ANTONIO PARISH

McKinley Road, Makati City 2004

GREENBELT CHAPEL

Esperanza Street corner Makati Avenue, Makati, 1228

ST. JOHN BOSCO PARISH CHURCH

Arnaiz Avenue corner Amorsolo Street Makati City

STS PETER AND PAUL PARISH

5539 D. M. Rivera Street, Poblacion, Makati City

ST. ANDREW THE APOSTLE PARISH

N. Garcia Street corner Kalayaan Ave. Bel-Air II, Makati City

FIRE STATIONS

MAKATI FIRE STATION

Ayala Avenue Extension corner Malugay Street, San Antonio, Makati City
(+632) 8813 2328

POLICE STATIONS

MAKATI POLICE DEPARTMENT

Ayala Avenue Extension corner Yakal Street, San Antonio, Makati City
(+632) 8887 2484 | 8843 5877

PRECINT 1

Taliba Street corner J.P. Rizal Street, Barangay Olympia, Makati City
(+632) 88897 9545

PRECINT 9

San Mateo corner P. Gomez Street, Barangay Poblacion, Makati City
(+632) 88899 3346

MALLS / CINEMAS

HIGH END SHOPPING MALLS

Rustan's & Glorietta, Makati City
Greenbelt 1-5, Makati City
Power Plant Mall, Rockwell, Makati City
Bonifacio High Street & Serendra, Taguig City
SM Mall of Asia, Pasay City
Century City Mall, Makati City

HANDICRAFTS & SOUVENIRS:

Balikbayan Handicrafts, Makati City
Tessoro's, Makati City
Kultura, SM Mega Mall, Makati City

Greenhills Shopping Center, San Juan City
Somewhat like a flea market, with stall after stall selling everything you can imagine. Take your time to look around and you'll find quality antiques and the best selection of genuine pearls in the country.

Market Market, Taguig City
5 levels with 520 stores

MUSEUMS & GALLERIES

AYALA MUSEUM

This gleaming museum features four floors of superbly curated exhibits on Filipino culture, art and history.

YUCHENGO MUSEUM

A mismatch among Makati's corporate high-rises, this fantastic art and design gallery was established by prominent businessman and former UN diplomat, Alfonso Yuchenco.

THE MIND MUSEUM

This world-class science museum succeeds in balancing education with fun, with plenty of cool interactive exhibits, including a planetarium, life-size T-Rex, remote control robots, fossil digs, hourly science experiments and 1980s arcade games.

MARKET

LEGAZPI SUNDAY MARKET

This laidback farmers markets has an array of local specialities. Here you'll find stalls serving cuisine from Filipino food-crazy regions such as Ilocos, Pampanga and Bicol, as well as French, Thai and Indonesian.

SALCEDO COMMUNITY MARKET

Held each Saturday morning, Salcedo Community Market is a great spot to hit for brunch with stalls selling everything from burgers and local desserts to a boggling array of grilled pork, and Filipino rice-flour pancakes known as bibingka, with a large communal dining area to dig in.

I'M HOTEL

Owned and Operated by Worldhotel Makati, Inc.
(+632) 7755 7888 | www.imhotel.com

I'M HOTEL

Owned and Operated by Worldhotel Makati, Inc.
(+632) 7755 7888 | www.imhotel.com



I'M HOTEL

Owned and Operated by Worldhotel Makati, Inc.
 (+632) 7755 7888 | www.imhotel.com